

Cartridge Style Pressure Reducing Valve

Taco's cartridge style pressure reducing valve sets a new standard for performance and serviceability. All the parts are contained in a one piece cartridge which can be easily removed and serviced without reducing line pressure. A one handed fast-fill button delivers increased flow to speed system fill times while its unique dial-in pressure setting allows for easy adjustment throughout the 10-50 psi range, without the need for an external gauge.



WATER CIRCULATION, FLOW CONTROL, AIR ELIMINATION, FLOW MEASUREMENT/BALANCING, ELECTRONIC CONTROLS

Do it once.
Do it right.

The logo consists of three horizontal wavy lines above the word 'Taco' in a bold, italicized, sans-serif font.

8 Reasons Why Installers Insist on Taco Pressure Reducing Valves



1. Engineering excellence packed with technical innovations.

- Use of a pressure balanced diaphragm makes the valve self compensating, ensuring incredible output pressure stability even when inlet pressure fluctuates severely.
- Use of a stainless steel spindle reduces erosion and corrosion ensuring that premium performance is maintained over the life of the valve.
- Use of an integral stainless steel coaxial strainer prevents system debris from affecting the valve's performance.
- Fully automated production line incorporates 100% testing and quality control checks on each valve.

2. Dial-up pressure setting eliminates the need for pressure gauges

- Highly accurate.
- Easy to adjust.
- Once set it is protected by a secure tamper-proof system.
- Setting is easy to read even in low light environments.
- 10 – 50 psi adjustment range.

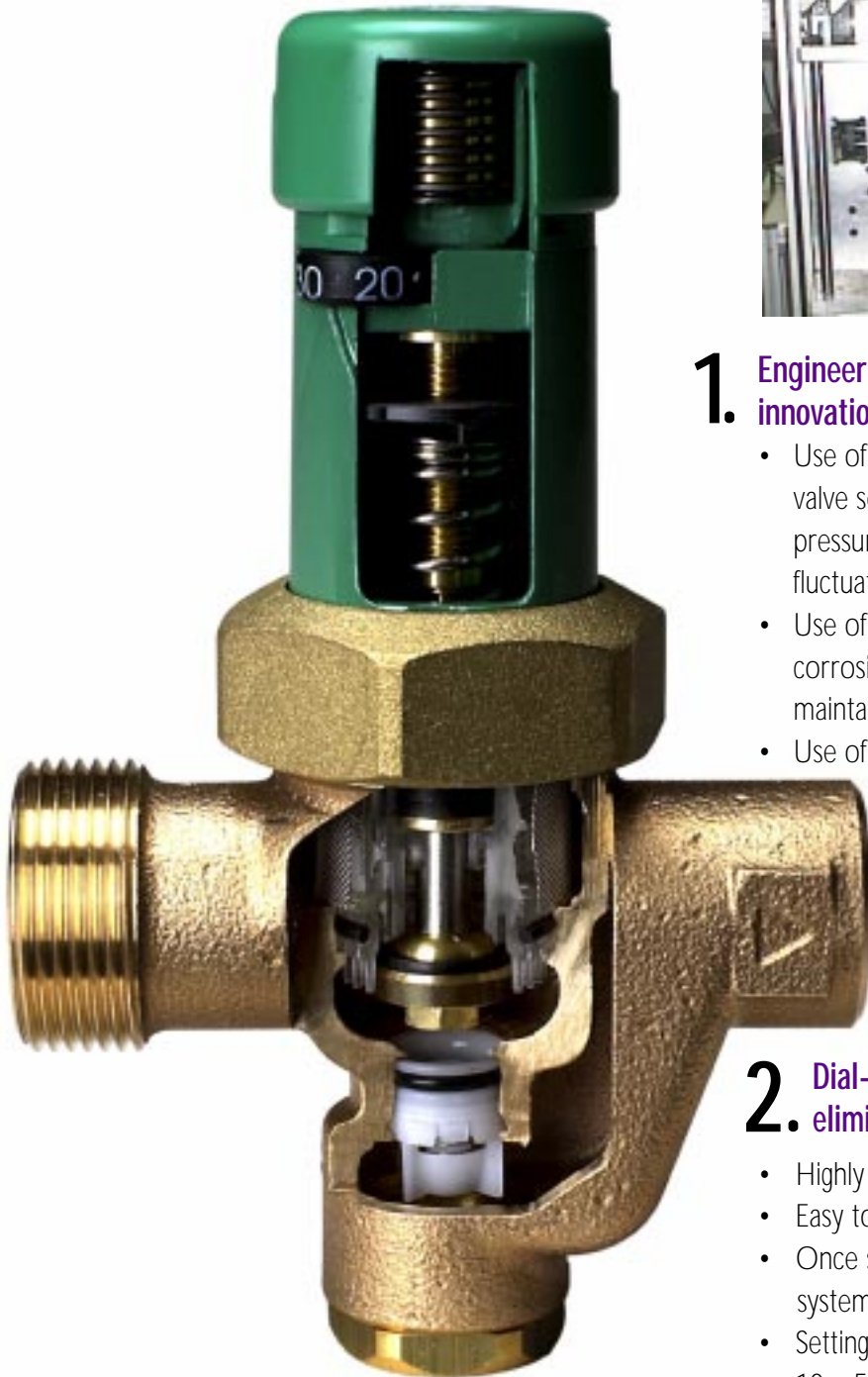

3. Meets or exceeds the most demanding technical standards

- ASSE 1003 Approved.
- Fully approved by the Water Research Council WRC.
- Exceeds the construction requirements of British Standard BS 6283 Pt.4.
- Meets the most demanding European Standard, Germany's DGVW.



4. Bubble-tight design maintains constant outlet pressure under flow and no flow conditions

- Achieved through balanced diaphragm construction.
- Ensures constant outlet pressure even at 230 psi.

5. Unique one-piece cartridge ensures rapid servicing and maintenance under pressure

- Unique valve design allows the cartridge to be removed under system pressure.
- One-piece cartridge design makes servicing the valve quick and easy – no small parts to handle or lose.
- The cartridge ensures that the correct pressure setting is kept during routine maintenance.
- Complete replacement cartridges can be purchased to minimize site down-time.



- Cartridge eliminates the need to drain the system or to replace an entire valve.
- Significantly reduces labor expense and install time compared to a conventional PRV.

6. Incredible Flow Rates and Fast Fill Button

- High C_v of 2.1.
- One-handed fast fill lever.
- Fastest fill rate.
- Cuts install time.

7. Patented "comb design" eliminates problems with excessive noise

- Maximum noise output of 20dB.
- Ordinary PRV's can be extremely noisy.
- The comb design also alters water flow turbulence to reduce cavitation.



8. Ease of installation & replacement of old valves

- Same dimensions as Taco and Watts PRV.
- Can be installed in any position.
- Cartridge can be rotated 360° so indicator is always visible.
- All-in-one direct female threaded and male union connection.
- Convenient 1/2" bottom tapping for Taco model 3180 pressure relief valve or an expansion tank.

Submittal Data Information Cartridge Style Pressure Reducing Valve

Purpose

To automatically feed water to a system whenever pressure in the system drops below the pressure setting of the valve.

Operation

The cartridge style design ensures unsurpassed output pressure stability. A balance between diaphragm position and spring tension based on the desired outlet pressure is consistently maintained, even when inlet pressures fluctuate severely. The unique one-piece cartridge design significantly reduces diaphragm load, extending the overall product life. Unlike conventional PRV designs, the diaphragm does not double

as a seal between the body and the cap. This allows for optimization of the diaphragm for its intended use - maintaining pressure stability. A unique encapsulated shaft seal system prevents flowing media from contacting the diaphragm, greatly extending diaphragm life. If the diaphragm ever does fail, the encapsulated shaft and body seals work together to stop water from exiting the valve. Use of a stainless steel coaxial strainer prohibits system debris from affecting the valves' performance. An integral check valve allows the cartridge to be removed under system pressure for replacement or servicing. A one-handed fast-fill lever speeds system filling time.

Ratings

Fast Fill Mode: 2.1 C_v
Media: Water

Materials of Construction

Body: Bronze
Internal Parts: Stainless Steel and Engineered Plastics

Certifications

ASSE 1003 Approved
Water Research Council Approved
Exceeds BS 6283 Pt.4
Meets Germany's DGWW
ISO 9001 Manufacturing Facility

Dimensions

Product Number	Size Description	Max. Inlet Pressure	Max. Fluid Temperature	Adjustment Range	Factory Preset	Dimensions				
						A	B	C	D	E
3350-T	1/2" NPT	230 psi	140°F	10-50 psi	12 psi	3 9/16"	3 3/4"	2"	1 5/8"	1 15/16"

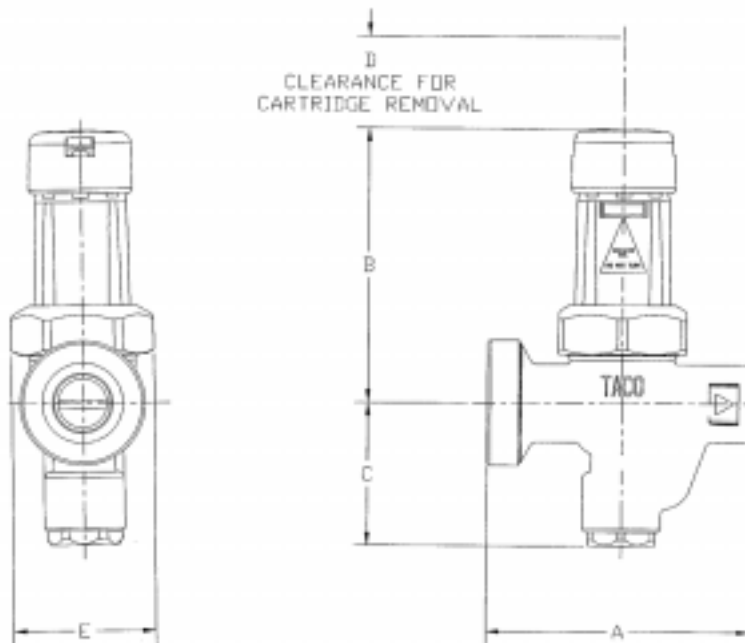

WATER CIRCULATION, FLOW CONTROL, AIR ELIMINATION, FLOW MEASUREMENT/BALANCING, ELECTRONIC CONTROLS

Do it once.
Do it right.



Taco Incorporated, 1160 Cranston Street, Cranston, RI 02920 / (401) 942-8000 / Fax (401) 942-2360
Taco (Canada) Ltd., 6180 Ordan Drive, Mississauga, Ontario L5T 2B3 / (905) 564-9422 / Fax (905) 564-9436
Internet: taco-hvac.com