



COMPARE. YOU'LL TAKE TACO.

## Model 009 Cartridge Circulator



- **Unique Replaceable Cartridge Design—Field Serviceable**
- **Unmatched Reliability—Maintenance Free**
- **Quiet, Efficient Operation**
- **Standard High Capacity Output—Compact Design**
- **Direct Drive—Low Power Consumption**
- **Universal Flange to Flange Dimension**
- **Manufactured in a Variety of Sizes to Match System Requirements**
- **Residential and Light Commercial Applications**

---

### **TACO, INC.**

1160 Cranston Street, Cranston, RI 02920  
Telephone (401) 942-8000 Telex: 92-7627

### **TACO (Canada) LTD.**

1310 Aimco Blvd., Mississauga, Ontario L4W 1B2  
Telephone (416) 625-2160 Telex: 06-961179

# "00" Series Cartridge Circulators

## Submittal Data Information



### APPLICATION

The Taco 009 Residential and Light Commercial Circulator is designed for use in high head hydronic heating systems and open loop fresh water applications. The cast iron 009 can be used in High Head Low Flow Hydronic Heating systems, Higher Head Radiant in Floor/Panel Heating systems, and High Head Closed Loop Solar systems. The bronze 009 can be used in Open Loop Solar systems, and Light Commercial Domestic

Hot Water Recirculation systems. The Unique Replaceable Cartridge contains all the moving parts, and allows the circulator to be serviced instead of replacing the entire unit. The Quieter Direct Drive cartridge type "00" Series circulator is self lubricating, contains no mechanical seal, and requires no maintenance. This compact, low power consumption design is ideal for those high efficiency jobs

### PUMP DIMENSIONS

	A		B		C		D		F		G		Shipping Weight	
	IN.	MM	IN.	MM	IN.	MM	IN.	MM	IN.	MM	IN.	MM	LBS.	KG
FLANGED	7 <sup>5</sup> / <sub>16</sub>	186	6	152	3 <sup>3</sup> / <sub>16</sub>	81	3 <sup>3</sup> / <sub>8</sub>	86	4 <sup>1</sup> / <sub>8</sub>	105	6 <sup>3</sup> / <sub>8</sub>	162	9.5	4.3
SWEAT	7	178	5 <sup>5</sup> / <sub>16</sub>	151	3 <sup>5</sup> / <sub>8</sub>	92	3 <sup>3</sup> / <sub>8</sub>	86	4 <sup>1</sup> / <sub>8</sub>	105	7 <sup>3</sup> / <sub>8</sub>	187	10	4.5

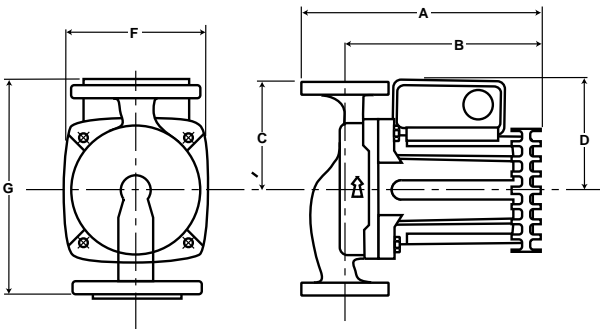

### SPECIFICATIONS UL & CSA LISTED

CASING	Cast Iron or Bronze
IMPELLER	Non-Metallic
SHAFT	Ceramic
BEARINGS	Carbon
CONNECTIONS	Flanged 3/4", 1", 1 1/4", 1 1/2" Sweat 3/4"
PRESSURE RATING	125 psi Maximum
TEMPERATURE RATING*	225°F Maximum
MOTOR TYPE	Permanent Split Capacitor
HP	1/15 HP @ 3250 RPM
ELECTRICAL CHAR:	115/60/1 1.30 Amp Rating Impedance Protected

\*Bronze Units Max. Temp. 200°F

### PERFORMANCE FIELD

