



## BUILT TO LAST

**Leak Proof.** Beryllium copper metal bellows separate system water from the atmosphere for positive and leak proof operation.

**Patented Construction.** Exclusive heat motor functions silently. Energy saver — heat motor is not constantly energized while the valve is open.

**Maintenance Free.** Heavy bronze body with sweat connections. Globe valve construction with E.P. seat ensures tight shut-off for trouble free service.

**Easy-To-Install.** Only 3 low voltage connections. Power head does not have to be removed to install.

**Factory Tested.** Every Taco Zone Valve is operated before shipment.

## PURPOSE

Designed for high head capacity applications. Save energy — cut fuel costs! Taco Zone Valves, each with its own thermostat, permit accurate temperature control of individual rooms or groups of rooms. Used primarily in high-rise residential and commercial buildings due to high pump head requirements.

## FEATURES

**Dependable-Quiet Operation** — Taco Zone Valves offer rugged dependability and absolutely silent operation.

**Heavy Duty Construction.**

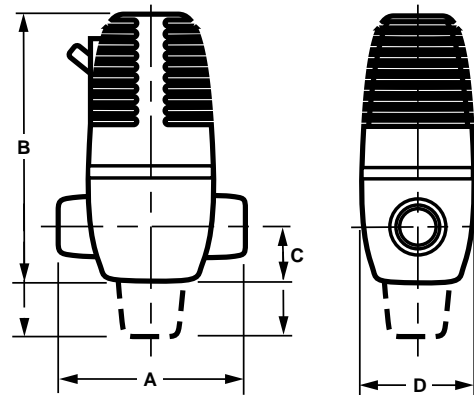

Prod. No.	Size Conn's. Ins.	Normal Flow Range GPM	Press. Drop Thru-Valve Ft. of Pipe equiv.	Pump Head Ft. of Water	Max. Work Press PSI	Oper. Temp. Range F.	Amp. Rating	Volts Frequency	Dimensions				Appr. Ship Wgt. Lbs.
									A	B	C	D	
555	1/2	1-4 1/2	10	150	125	40-240	0.9	24V-60Hz	3 1/16	5 3/8	1 1/16	2	2 1/8
556	1/4	4 1/2-6	20						3 3/8	5 3/8	1 1/16	2	2 1/4
557	1	6-10	60						3 3/8	5 3/8	1 1/16	2	2 1/4