

### Flo-Chek

Taco Flo-Cheks have dependably stopped gravity circulation in forced hot water heating systems for over 40 years. Flo-Cheks open automatically when the circulator starts running. They feature a thumb screw to manually open the valve, and are available in a cast iron universal body and a bronze sweat in-line configuration. A unique, re-designed weighted check on the 221 and 222 models features an enhanced seating and quieter operation on high flow systems.



WATER CIRCULATION, FLOW CONTROL, AIR ELIMINATION, FLOW MEASUREMENT/BALANCING, ELECTRONIC CONTROLS

Do it once.  
Do it right. 

# Submittal Data Information Flo-Chek

## Purpose

Taco Flo-Cheks are used in a forced hot water heating system to prevent "gravity" circulation during periods when the boiler is hot but the space heating zone is not wanted. This makes it possible for the use of the heating boiler to maintain domestic hot water year round. In systems with multiple circulator zones, Flo-Cheks allow heat to flow only into the zones that are calling for heat. Also, the thumb screw can be manually opened for gravity feed applications if the main circulator stops operating.

## Operation

Taco Flo-Cheks open automatically when the circulator starts running. When the

room thermostat is satisfied and the circulator is stopped, the Flo-Cheks close immediately, preventing gravity circulation. Gravity circulation of water is induced by the difference in specific weight or density of the hot water in the vertical supply pipe and the cold water in the vertical return pipe. The lighter hot supply side water, which naturally wants to rise, is drawn up and around the system by the "pulling down" effect of the heavier cold water in the vertical return pipe. The amount of gravity circulation is dependent on the height of the system and the differential between the hot and cold temperatures. In systems with multiple zones, "ghost flow" may occur if a Flo-Chek is not installed on each zone.

Ghost flow is induced when a circulator on one zone is running but is still able to bypass water through a zone that is not calling, due to a differential in piping resistance between the two zones.

## Size and Connections

Available in 3/4" and 1" bronze sweat in-line design or 3/4" - 2" cast iron universal threaded body design. The Taco MPV can be used for sizes above 2".

## Ratings

Maximum Operating Pressure:  
125 PSI (862 kPa)

Maximum Operating Temperature:  
277°F (136°C)

Media: Water or Water / Glycol

Sweat In-Line

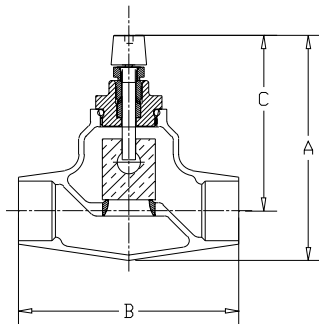

Cast Iron Universal Threaded

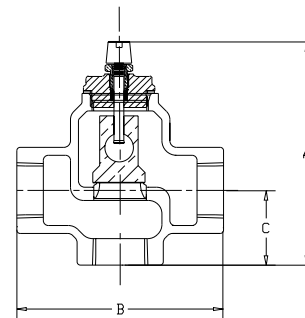

## Dimensions

Product Number	Size	Body	Type	Connections		Dimensions			Resistance in Feet Of Pipe Equivalent * / Cv	Shipping Weight	
				Inlet	Outlet	A	B	C		Lbs.	Kg.
219	3/4"	Bronze	Horiz.	Sweat	Sweat	3 3/2	3 3/8	2 7/16	143 / 2.5	1.1	0.5
241	1"	Bronze	Horiz.	Sweat	Sweat	4 11/16	4 1/4	3 3/4	63.4 / 7.7	1.8	0.8
218	3/4"	C.I.	Univ.	NPT	NPT	4 29/32	3 29/32	1 7/16	35.8 / 5	1.1	0.5
220	1"	C.I.	Univ.	NPT	NPT	5	4 1/4	1 9/16	83.7 / 6.7	3	1.4
221	1 1/4"	C.I.	Univ.	NPT	NPT	5 11/16	4 3/4	2	47.8 / 17	4.8	2.2
222	1 1/2"	C.I.	Univ.	NPT	NPT	6 13/32	6	2 3/8	57.9 / 23.5	7.8	3.5
223	2"	C.I.	Univ.	NPT	NPT	7	6 3/4	2 5/8	61.8 / 43.8	10.3	4.7

\*Data shown is based on flow rates @ 4 ft/sec velocity

WATER CIRCULATION, FLOW CONTROL, AIR ELIMINATION, FLOW MEASUREMENT/BALANCING, ELECTRONIC CONTROLS



Taco Incorporated, 1160 Cranston Street, Cranston, RI 02920 / (401) 942-8000 / Fax (401) 942-2360  
Taco (Canada) Ltd., 6180 Ordan Drive, Mississauga, Ontario L5T 2B3 / (905) 564-9422 / Fax (905) 564-9436  
Internet: [taco-hvac.com](http://taco-hvac.com)